

## Soft Seating - 2 Tier

### OVERVIEW

Soft Seating variations include work surfaces, different back heights, with or without arms on either side, as well as a large variety of shapes and sizes.

### FRAMES AND WEBBING

Frames are made of 3/4" CDX plywood with 2" x 7/8" air dried poplar hardwood for internal applications. Glue used in framing is Hi-Tac water-based wood adhesive. Arms and Backs (when applicable) are attached to seat frames with multiple 5/16" x 18 T-nuts and 5/16" x 18 x 2" NC Grade A RoHS compliant bolts with RoHS compliant 5/16" flat washers. Framing wood is stapled with both wide crown framing Staples, 1" crown x 5/8" length galvanized, and regular framing staples, 5/16" crown x 1 1/2" length galvanized.

Matrex Sytex engineered Y 370 3" webbing is used for seat and back suspensions and attached with 1/2" crown x 1/2" length fine wire galvanized staples.

### FOAM

Seat foam core is 2.0" 2.5 density 45 ILD.

All other foam core is 0.5" 1.8 density 33 ILD.

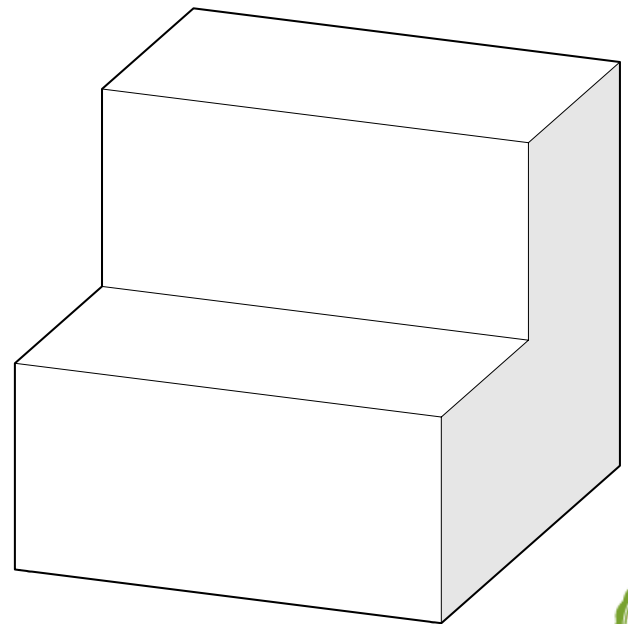

### STITCHING AND UPHOLSTERY

Top stitching (double stitching) on all upholstered items. A minimum of 7 stitches per inch. All threads are Tristar Nylbond HB 16 oz.

Upholstery by Momentum, Mayer, Spradling, and Culp is offered for all of our soft seating options. Upholstery is attached with 3/8" x 3/8" length fine wire galvanized staples and is protected with the Elite 200 dust cover.

### COMPLIANCE

Bolts and washers used in framing are Grade A RoHS Compliant

Plywood Frames are CARB II Compliant

Fully meets CA 117-2013 standards

### LAMINATE OPTIONS:

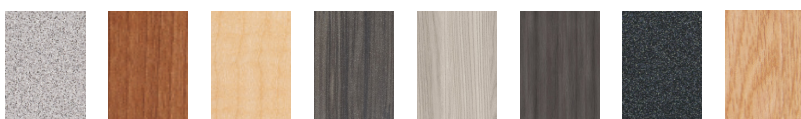

Grey Nebula Amber Cherry Fusion Maple Asian Night Grey Elm Low Line Graphite Nebula Castle oak

### EDGE COLORS:



Black Dove Gray White

# Dimensions

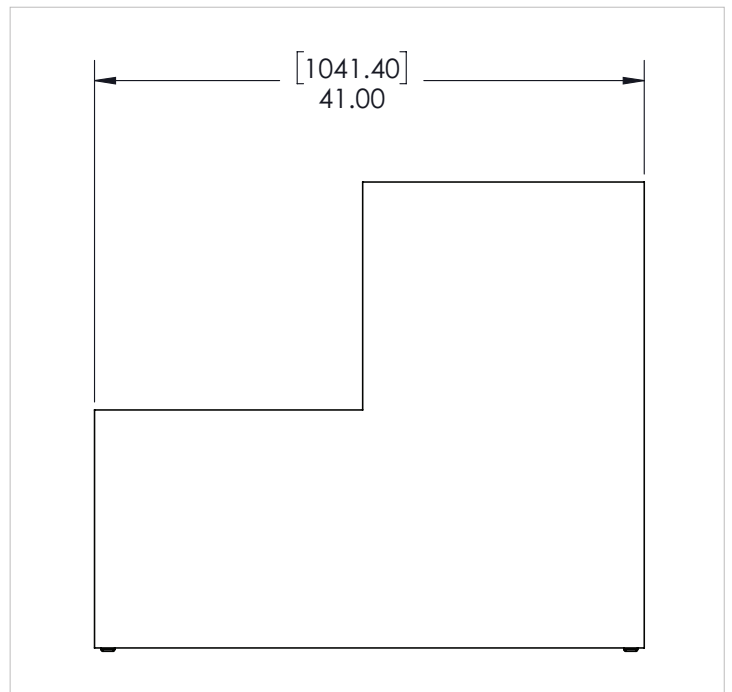
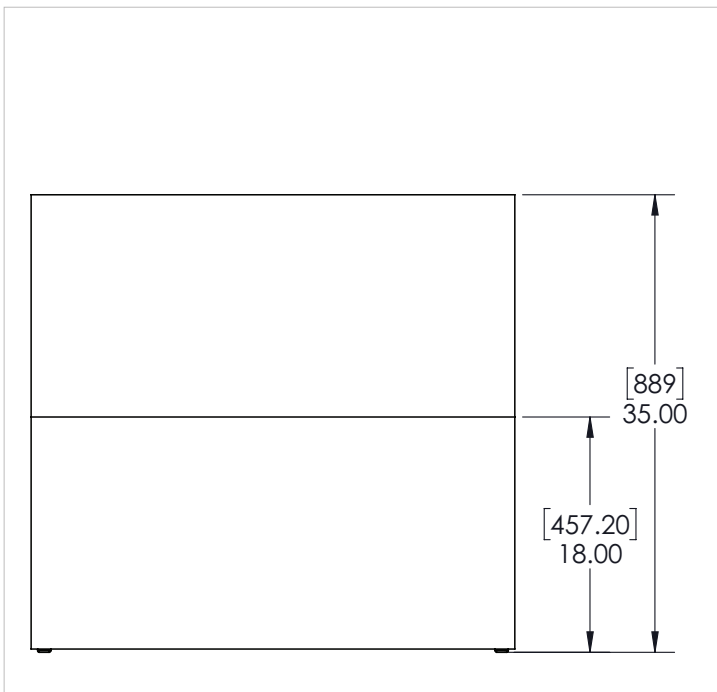
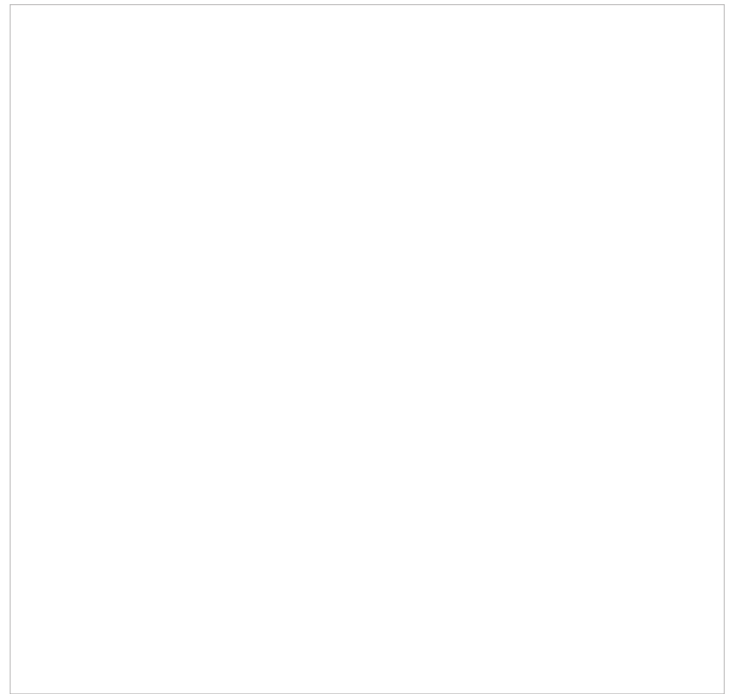
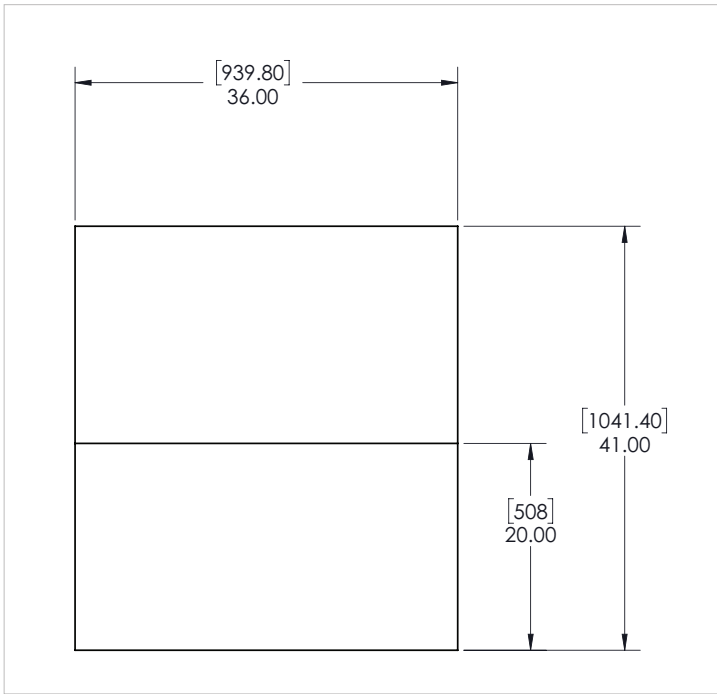

## Soft Seating - 3 Tier

### OVERVIEW

Soft Seating variations include work surfaces, different back heights, with or without arms on either side, as well as a large variety of shapes and sizes.

### FRAMES AND WEBBING

Frames are made of 3/4" CDX plywood with 2" x 7/8" air dried poplar hardwood for internal applications. Glue used in framing is Hi-Tac water-based wood adhesive. Arms and Backs (when applicable) are attached to seat frames with multiple 5/16" x 18 T-nuts and 5/16" x 18 x 2" NC Grade A RoHS compliant bolts with RoHS compliant 5/16" flat washers. Framing wood is stapled with both wide crown framing Staples, 1" crown x 5/8" length galvanized, and regular framing staples, 5/16" crown x 1 1/2" length galvanized.

Matrex Sytex engineered Y 370 3" webbing is used for seat and back suspensions and attached with 1/2" crown x 1/2" length fine wire galvanized staples.

### FOAM

Seat foam core is 2.0" 2.5 density 45 ILD.

All other foam core is 0.5" 1.8 density 33 ILD.

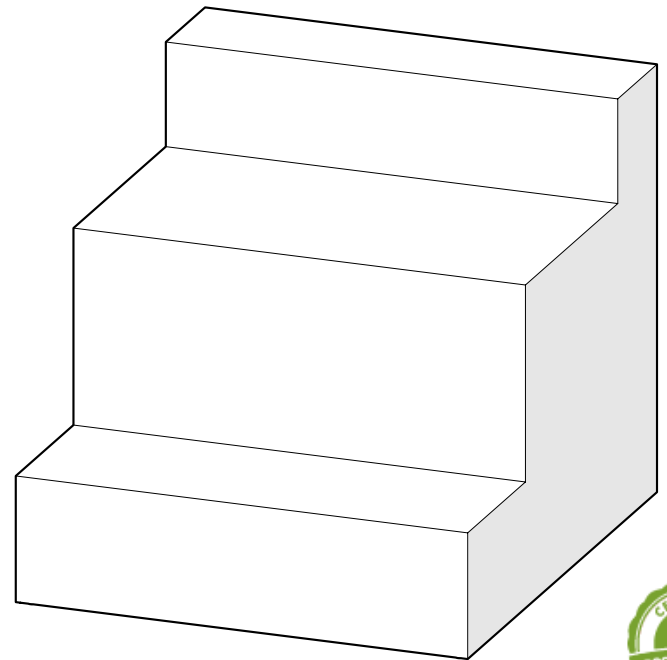

### STITCHING AND UPHOLSTERY

Top stitching (double stitching) on all upholstered items. A minimum of 7 stitches per inch. All threads are Tristar Nylbond HB 16 oz.

Upholstery by Momentum, Mayer, Spradling, and Culp is offered for all of our soft seating options. Upholstery is attached with 3/8" x 3/8" length fine wire galvanized staples and is protected with the Elite 200 dust cover.

### COMPLIANCE

Bolts and washers used in framing are Grade A RoHS Compliant

Plywood Frames are CARB II Compliant

Fully meets CA 117-2013 standards

### LAMINATE OPTIONS:

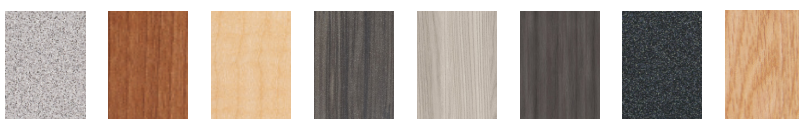

Grey Nebula Amber Cherry Fusion Maple Asian Night Grey Elm Low Line Graphite Nebula Castle oak

### EDGE COLORS:



Black Dove Gray White

# Dimensions

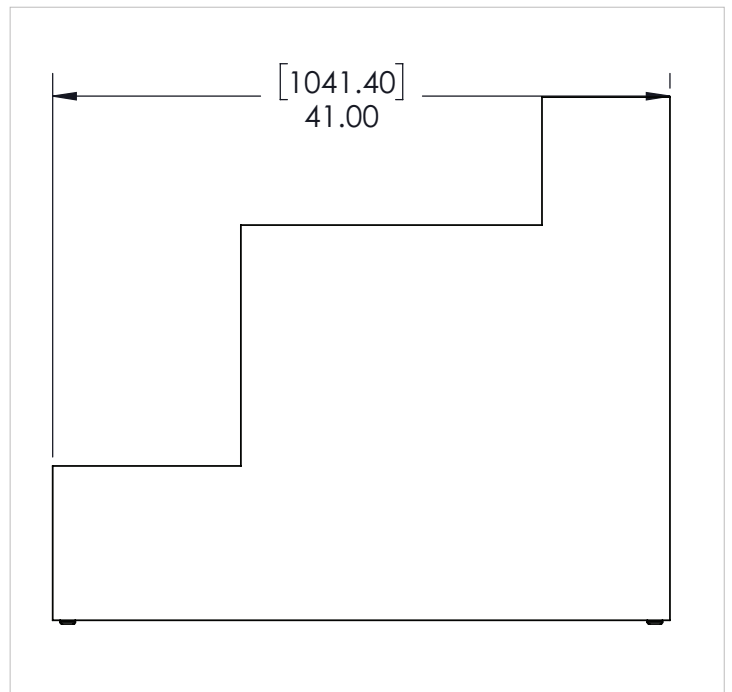
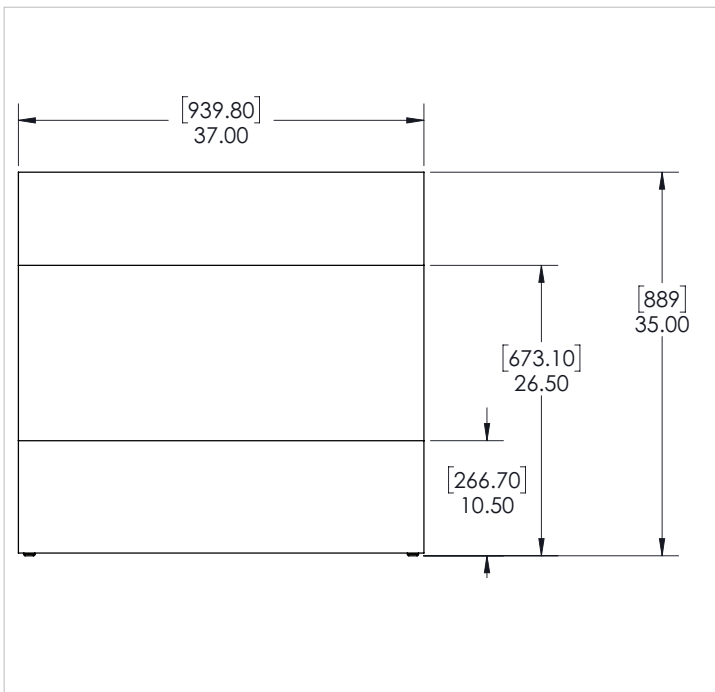
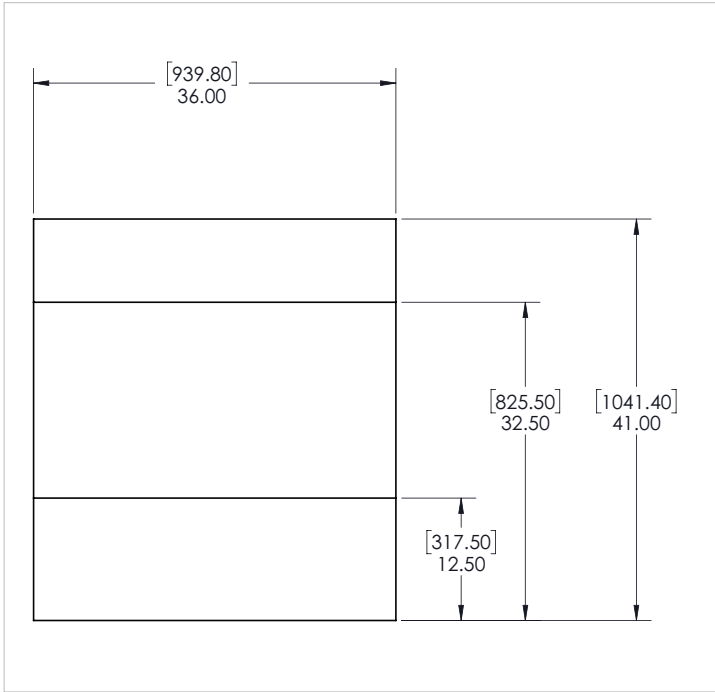

## Soft Seating - Inside Corner

### OVERVIEW

Soft Seating variations include work surfaces, different back heights, with or without arms on either side, as well as a large variety of shapes and sizes.

### FRAMES AND WEBBING

Frames are made of 3/4" CDX plywood with 2" x 7/8" air dried poplar hardwood for internal applications. Glue used in framing is Hi-Tac water-based wood adhesive. Arms and Backs (when applicable) are attached to seat frames with multiple 5/16" x 18 T-nuts and 5/16" x 18 x 2" NC Grade A RoHS compliant bolts with RoHS compliant 5/16" flat washers. Framing wood is stapled with both wide crown framing Staples, 1" crown x 5/8" length galvanized, and regular framing staples, 5/16" crown x 1 1/2" length galvanized.

Matrex Sytex engineered Y 370 3" webbing is used for seat and back suspensions and attached with 1/2" crown x 1/2" length fine wire galvanized staples.

### FOAM

Seat foam core is 2.0" 2.5 density 45 ILD.

All other foam core is 0.5" 1.8 density 33 ILD.

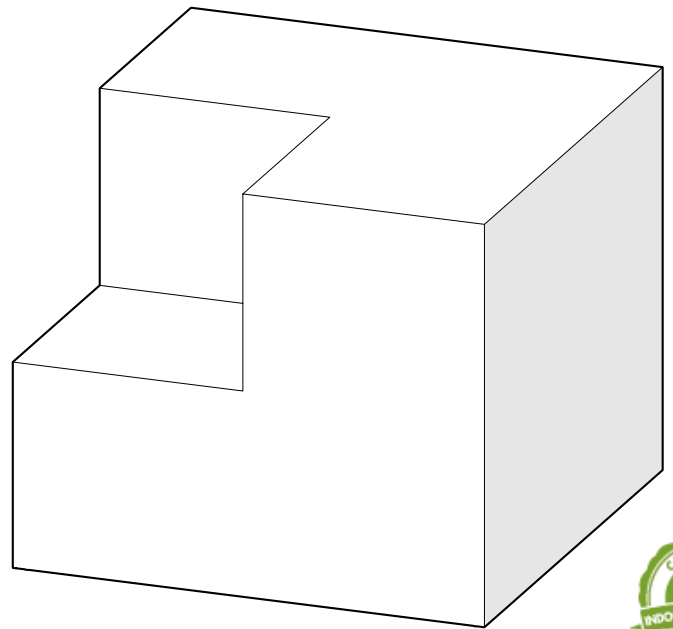

### STITCHING AND UPHOLSTERY

Top stitching (double stitching) on all upholstered items. A minimum of 7 stitches per inch. All threads are Tristar Nylbond HB 16 oz.

Upholstery by Momentum, Mayer, Spradling, and Culp is offered for all of our soft seating options. Upholstery is attached with 3/8" x 3/8" length fine wire galvanized staples and is protected with the Elite 200 dust cover.

### COMPLIANCE

Bolts and washers used in framing are Grade A RoHS Compliant

Plywood Frames are CARB II Compliant

Fully meets CA 117-2013 standards

### LAMINATE OPTIONS:

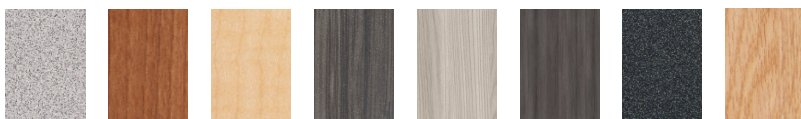

Grey Nebula Amber Cherry Fusion Maple Asian Night Grey Elm Low Line Graphite Nebula Castle oak

### EDGE COLORS:



Black Dove Gray White

# Dimensions

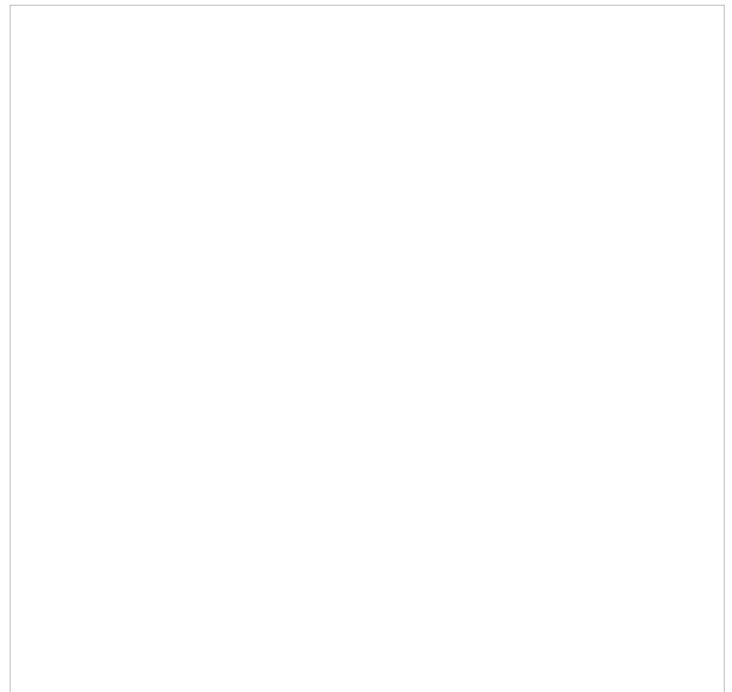
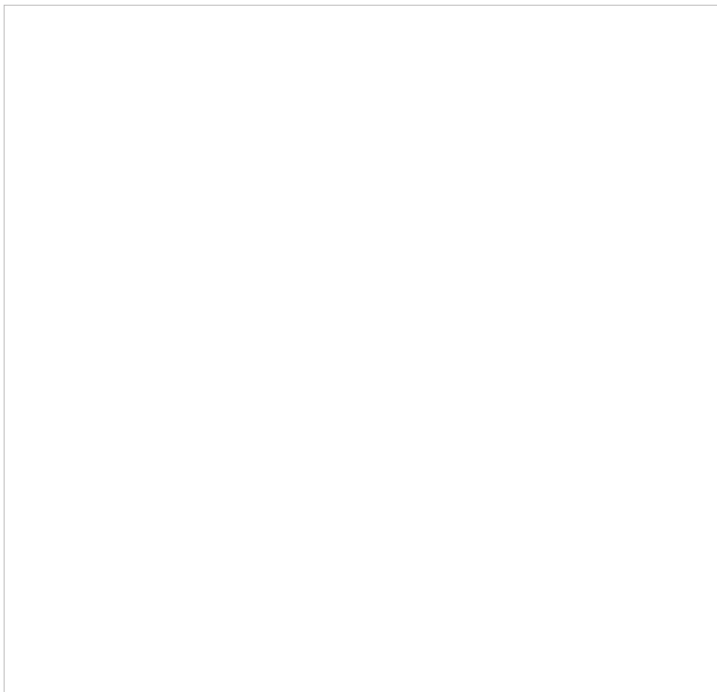
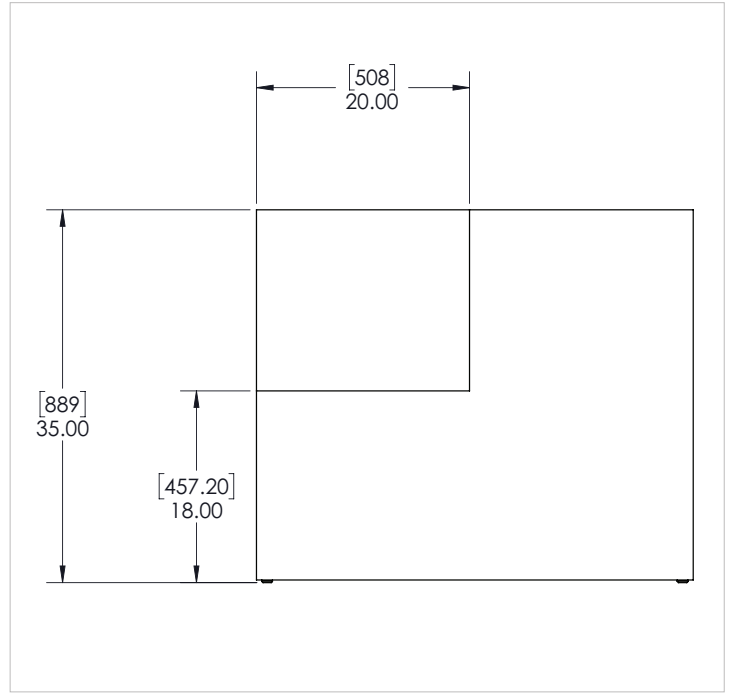
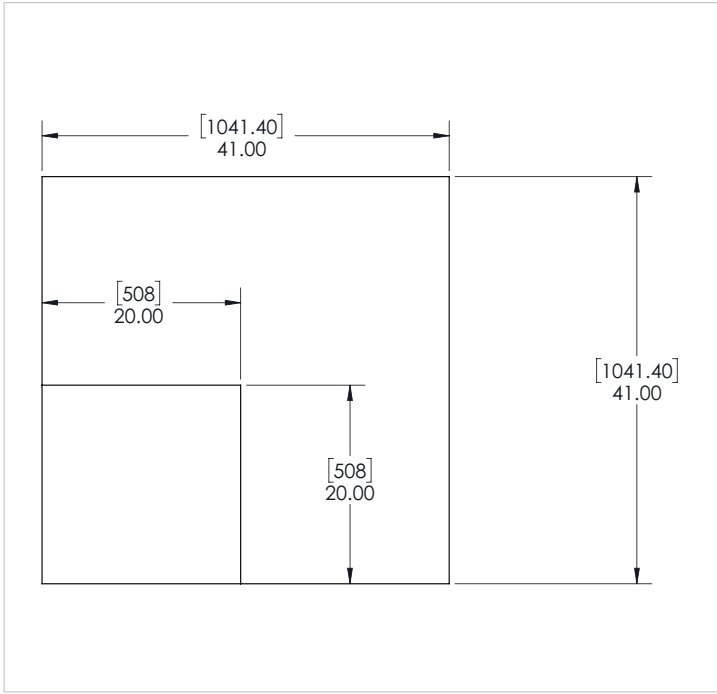

## Soft Seating - Outside Corner

### OVERVIEW

Soft Seating variations include work surfaces, different back heights, with or without arms on either side, as well as a large variety of shapes and sizes.

### FRAMES AND WEBBING

Frames are made of 3/4" CDX plywood with 2" x 7/8" air dried poplar hardwood for internal applications. Glue used in framing is Hi-Tac water-based wood adhesive. Arms and Backs (when applicable) are attached to seat frames with multiple 5/16" x 18 T-nuts and 5/16" x 18 x 2" NC Grade A RoHS compliant bolts with RoHS compliant 5/16" flat washers. Framing wood is stapled with both wide crown framing Staples, 1" crown x 5/8" length galvanized, and regular framing staples, 5/16" crown x 1 1/2" length galvanized.

Matrex Sytex engineered Y 370 3" webbing is used for seat and back suspensions and attached with 1/2" crown x 1/2" length fine wire galvanized staples.

### FOAM

Seat foam core is 2.0" 2.5 density 45 ILD.

All other foam core is 0.5" 1.8 density 33 ILD.

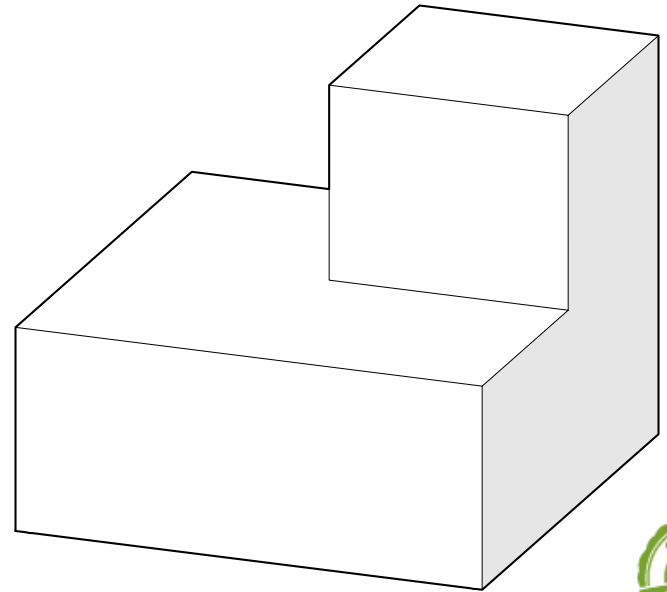

### STITCHING AND UPHOLSTERY

Top stitching (double stitching) on all upholstered items. A minimum of 7 stitches per inch. All threads are Tristar Nylbond HB 16 oz.

Upholstery by Momentum, Mayer, Spradling, and Culp is offered for all of our soft seating options. Upholstery is attached with 3/8" x 3/8" length fine wire galvanized staples and is protected with the Elite 200 dust cover.

### COMPLIANCE

Bolts and washers used in framing are Grade A RoHS Compliant

Plywood Frames are CARB II Compliant

Fully meets CA 117-2013 standards

### LAMINATE OPTIONS:

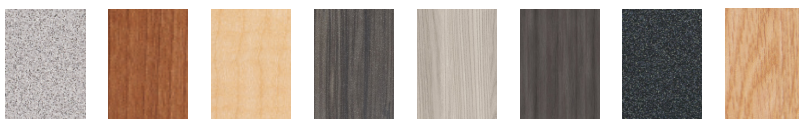

Grey Nebula Amber Cherry Fusion Maple Asian Night Grey Elm Low Line Graphite Nebula Castle oak

### EDGE COLORS:



Black Dove Gray White

# Dimensions

