

Mobile Teacher Workstation II

Model No: 91289-XXXX-XX

OVERVIEW

Features a durable and curved HPL top available in a variety of top finishes and edgebands with a platinum steel base.

TOP

The top is made of 1 1/8" Particleboard Core with 3mm Flat Vinyl T-Mold Edge. The work surface is constructed of 45# particleboard core with high pressure laminate (HPL) top surface and phenolic backer sheet for balanced construction. 1 1/8" 3mm flat vinyl t-mold is secured to the work surface with brad nails along the perimeter.

FRAME/PEDESTAL

The frame is made up of a double leg assembly that features welded angle brackets for added stability. The main leg piece, with two 1.5" diameter 16Ga steel legs, fits into a bracket and is fastened using four M6 x 32mm through bolts. This assembly attaches to the table top using eight M6 x 12mm screws. The cabinet pedestal is made of 16Ga Steel and measures 18.0"W x 17.75"D x 31.5"H. It is attached to the table top with four 3.69" long standoffs using four M6 x 32mm screws and four M6 x 25mm all-thread bolts. The frame sits on six 3" dual wheel casters (three locking) with 15mm stems and lock washers. The hinging door compartment on the pedestal has a single height adjustable shelf (15.3" x 16.3").

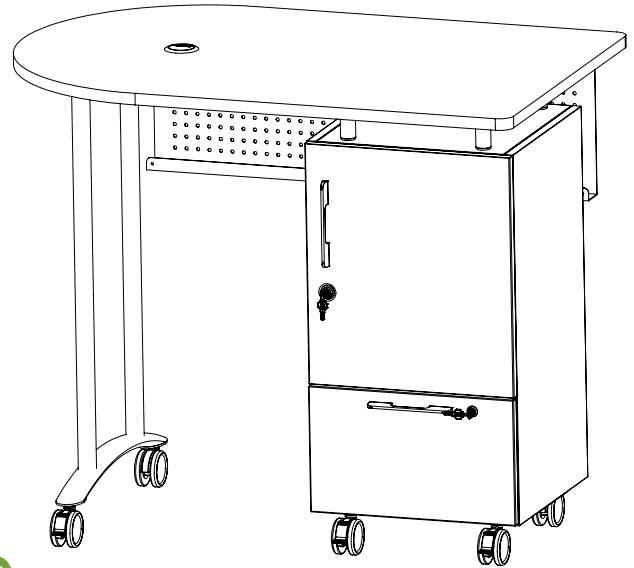

OPTIONS / ACCESSORIES

The Pop-Up Grommet Outlet & USB Charger can provide desktop power and charging accessibility.

A 16-gauge perforated steel modesty panel attaches to top with five wood screws (sold separately).

The Mobile Teacher Workstation II can have a Locking Pencil Drawer attached underneath on either side for documents, pens, and other small items.

LAMINATE OPTIONS:



Amber Cherry Asian Night Castle Oak Fusion Maple Graphite Nebula Gray Elm Gray Nebula Low Line White Board

EDGE BAND COLORS:



Black Platinum Cool Gray Purple Navy Blue Green Yellow Orange Red

FRAME/PANEL:



Platinum

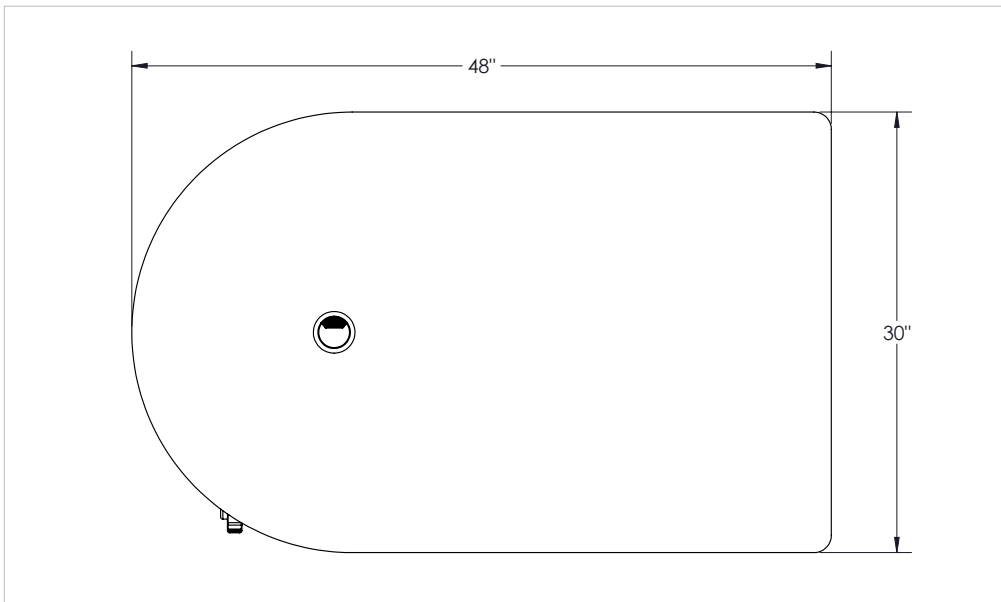
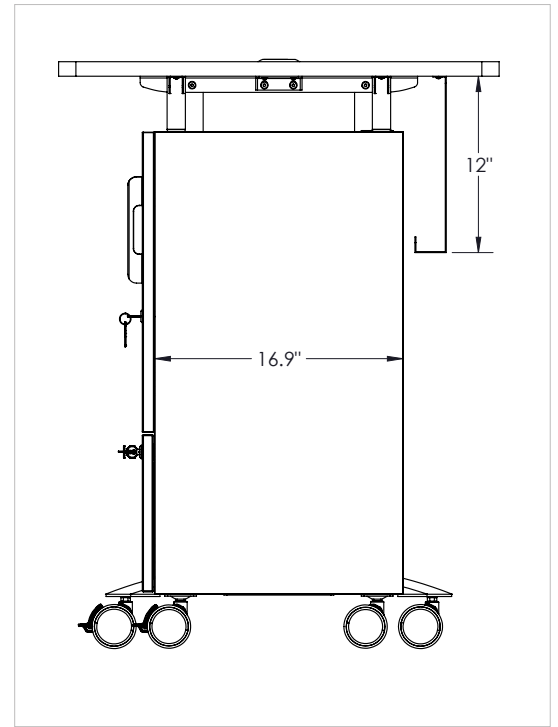
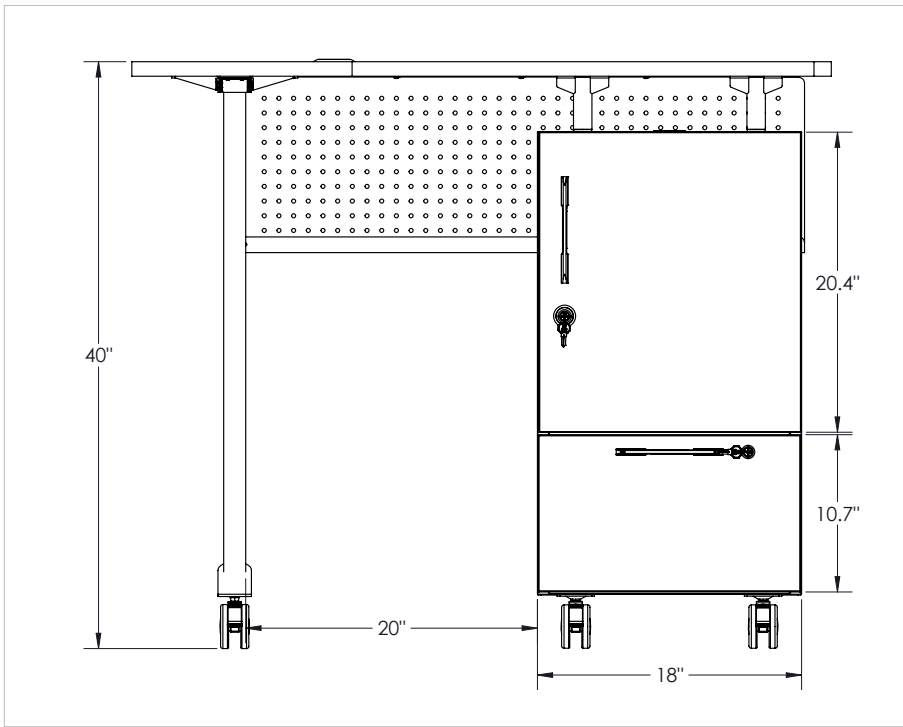

DIMENSIONS:

Base Model No.	Description	Dimensions
91289-XXXX-XX	Mobile Teacher Workstation II	40"H x 47.6"W x 30"D

ACCESSORIES:

Base Model No.	Description	Dimensions
91290	Mobile Teacher Workstation II - Optional Modesty Panel	10.3"H x 40"W
66666	Pop-Up Grommet & USB Charger	29"H x 60"W x 36.25"D
34443	Accessory Locking Pencil Drawer	3.5"H x 15.5"W x 12.5"D



MooreCo | Vanerum North America
 2885 Lorraine Avenue | Temple, TX 76501
 p: 800.749.2258 | f: 866.888.7483
www.moorecoinc.com | www.vanerumnorthamerica.com