

STEP 3

Position Crossbrace with Uprights in between Mount Inserts and line up holes. Secure with screws (B) and washers and cap with lock nut. Inserts should be level with Crossbrace after tightening.

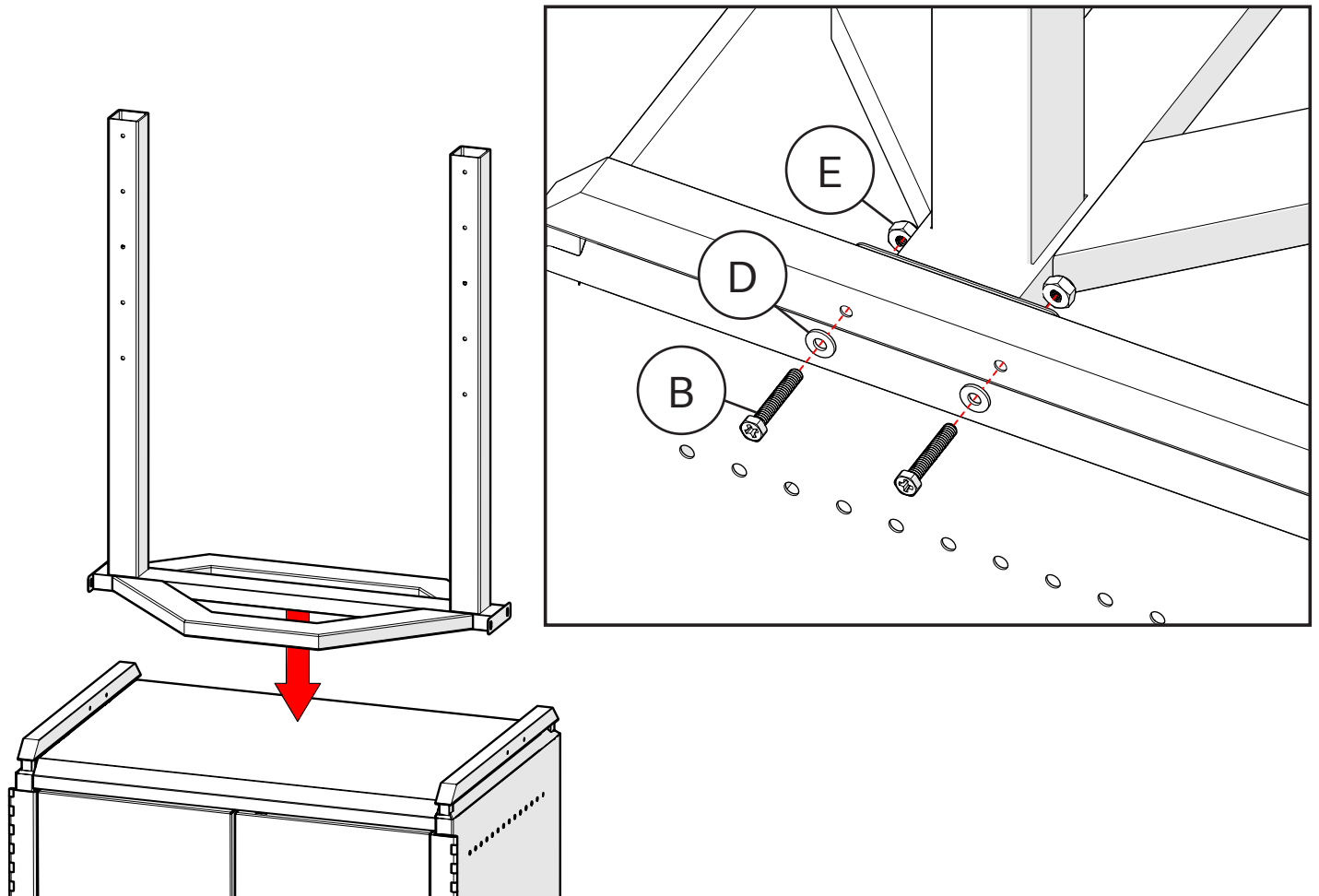

STEP 4

Replace all casting retainer screws removed in Step 2.

If unable to thread screws, inserts are not at correct height and need adjusting.

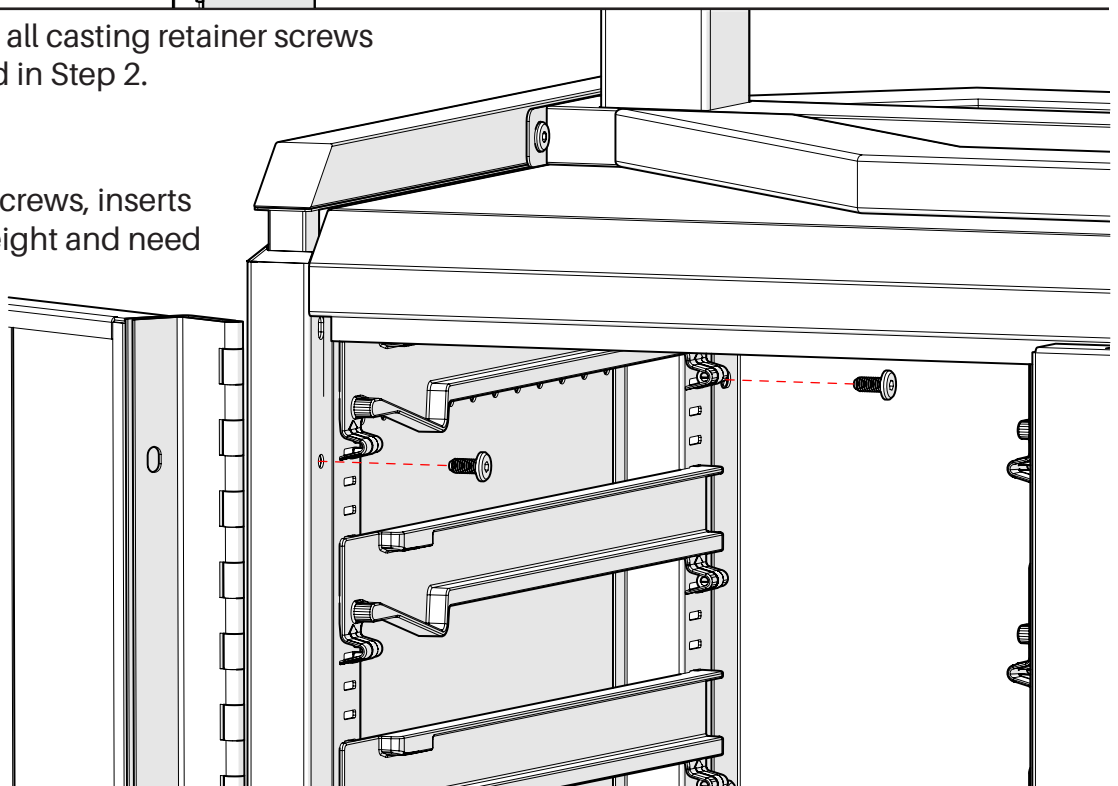

STEP 5

Attach Mount Frame to Uprights at desired height with washers and screws (C). See chart for panel display size & weight limits at high and low settings for both cabinet sizes (2 wide with highest setting shown).

2 WIDE	Max Size (Diagonal)	Max Weight
Lowest Setting	70"	150 lbs
Highest Setting	85"	110 lbs

3 WIDE	Max Size (Diagonal)	Max Weight
Lowest Setting	70"	160 lbs
Highest Setting	85"	120 lbs

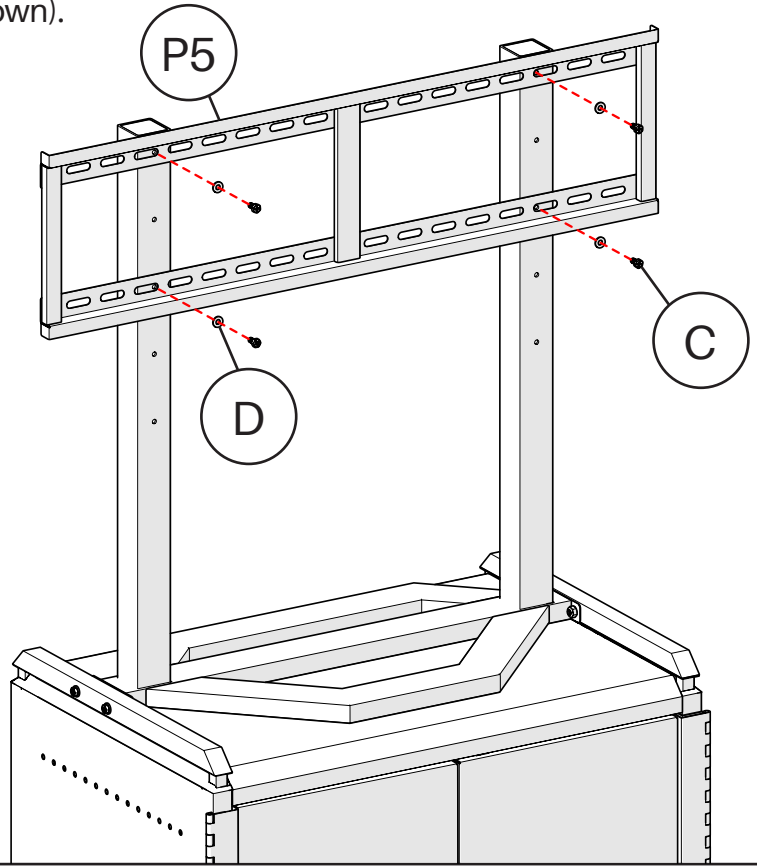

STEP 6

Attach TV Mount Brackets to back of flat panel display with necessary hardware (not provided). Brackets should be oriented as shown and centered on display.

WORKS WITH VESA SIZES:

75 x 75
 100 x 100
 200 x 100
 200 x 200
 300 x 200
 300 x 300
 400 x 200
 400 x 300
 400 x 400
 600 x 400
 800 x 600

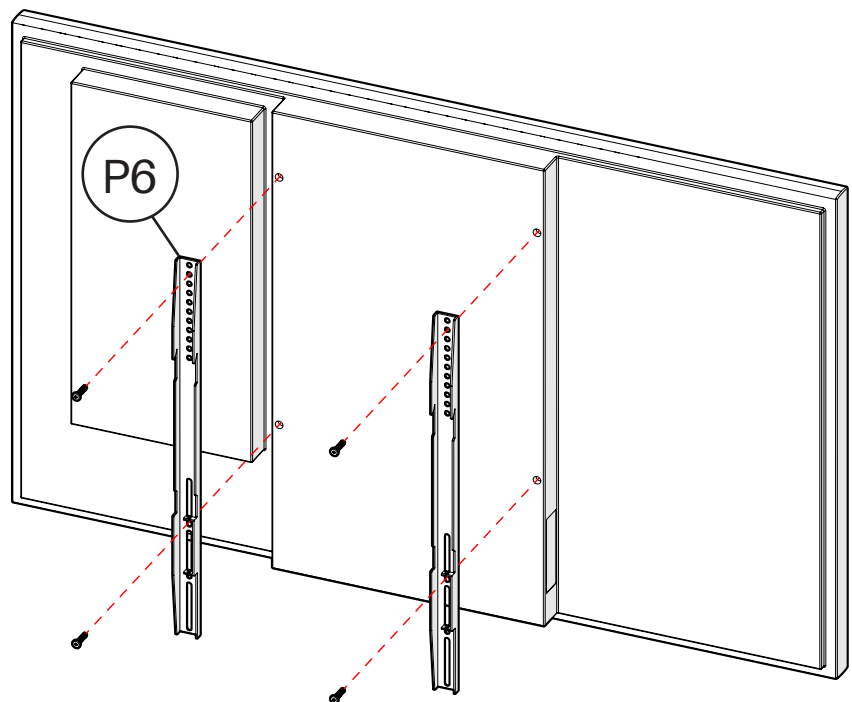

STEP 7

Hang Flat Panel on TV Mount by first hooking top of brackets to Mount Frame. Secure in place by inserting screws (D) through holes on brackets and tightening into Mount Frame until snug.

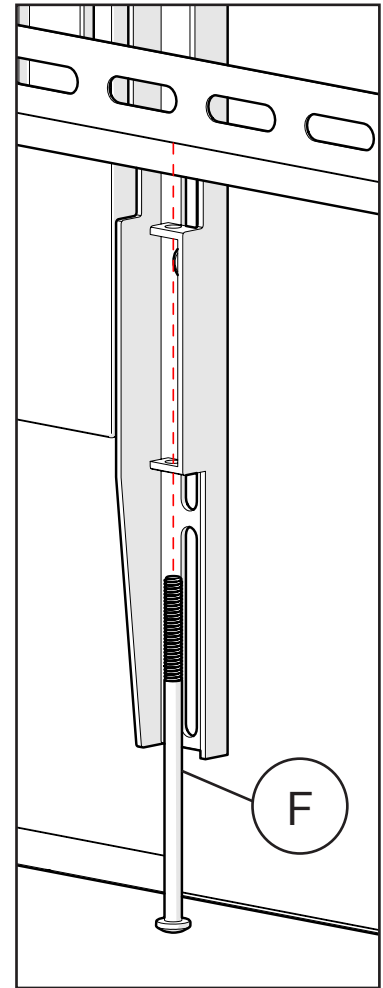
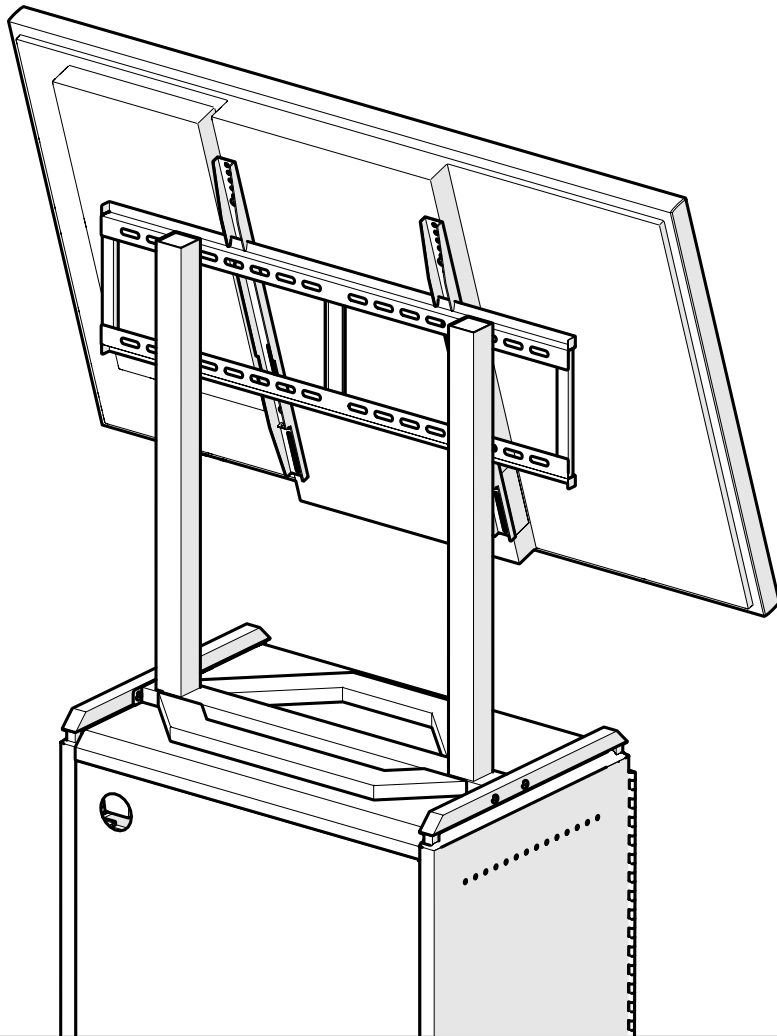

THIS COMPLETES ASSEMBLY INSTRUCTION