

\* Side panels shown with optional bag hooks



**ASSEMBLY INSTRUCTIONS**  
DO NOT THROW AWAY!



**INSTRUCCIONES DE ENSEMBLAJE**  
NO LA TIRE

**INSTRUCTIONS DE MONTAGE**  
NE PAS JETER

## Parts List

Top

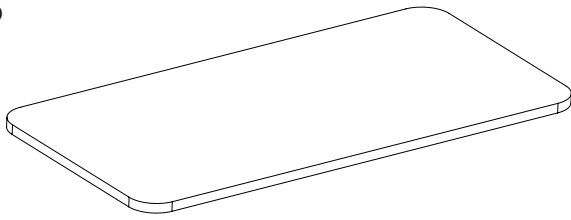

x 1

Side Panel (shown with optional bag hooks)

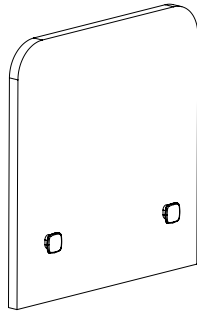

x 2

Modesty Panel

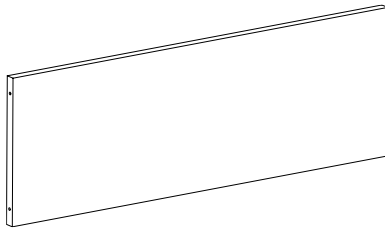

x 2

## Hardware

Cam Bolt



x 16

Cam Insert

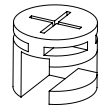

x 16

Dowel Insert



x 16

## STEP 1

Install cam bolt hardware into both side panels. For each panel:

- a. Dowel inserts go into the four central holes, followed by cam bolts threading into the dowel inserts.
- b. Cam inserts go into the four holes along the top edge of the side panel.

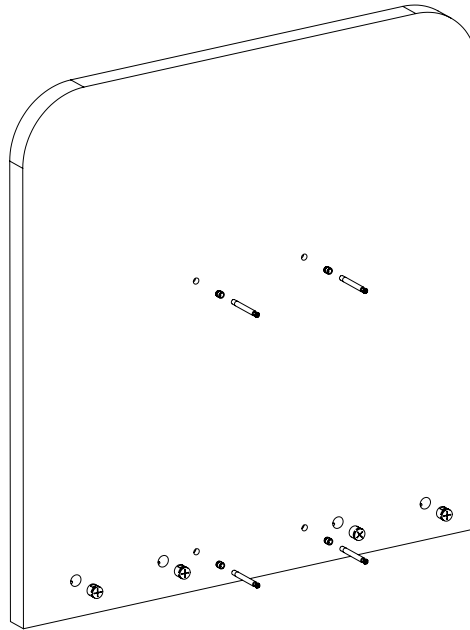

## STEP 2

Insert cam inserts into the four holes on each of the modesty panels.

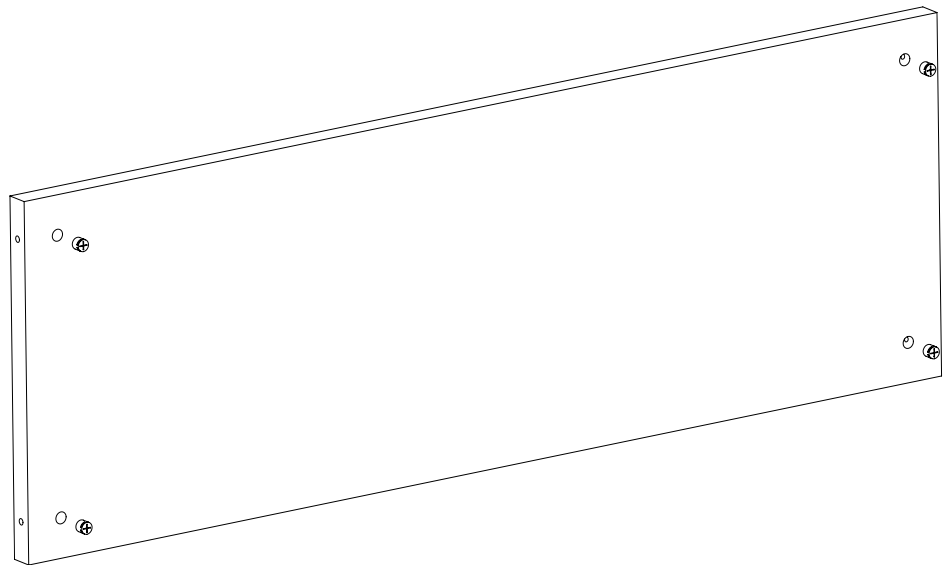

## STEP 3

Slide modesty panel onto cam bolts on one of the side panels and tighten cam locks. Repeat process for the second modesty panel.

**\*NOTE\*** Hardware to face inwards.

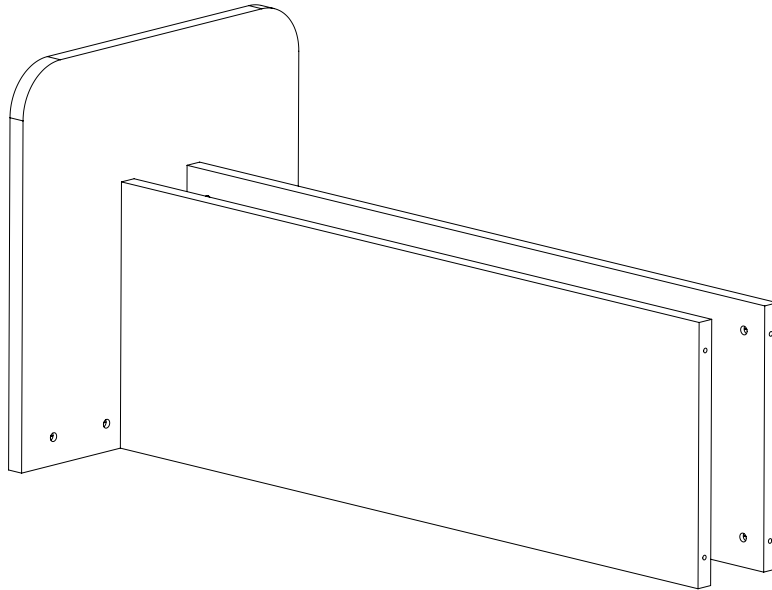

## STEP 4

Slide second end panel into opposite end of modesty panels and tighten cam locks.

**\*** Side panels shown with optional bag hooks

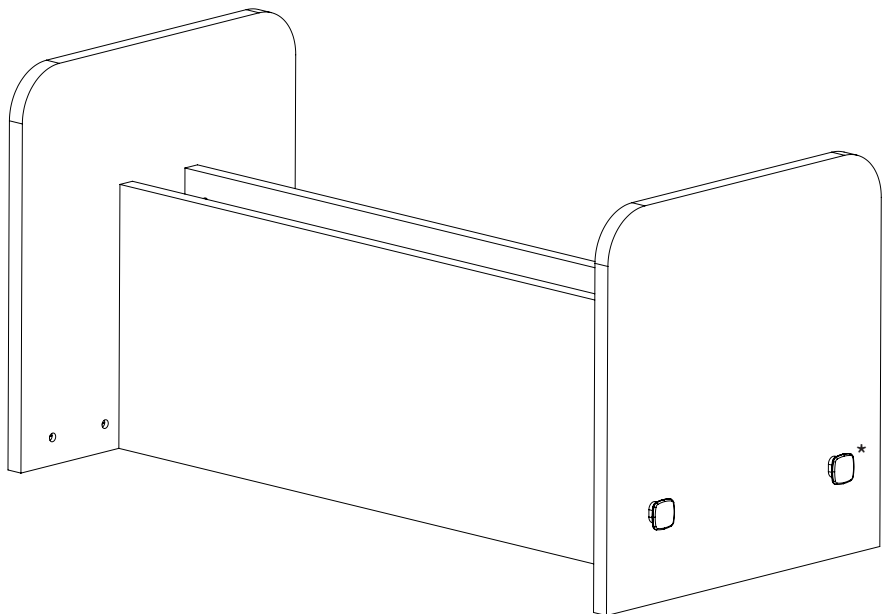

## STEP 5

Install cam bolt hardware into underside of table top. Dowel inserts go into each hole, followed by cam bolts threading into the dowel inserts.

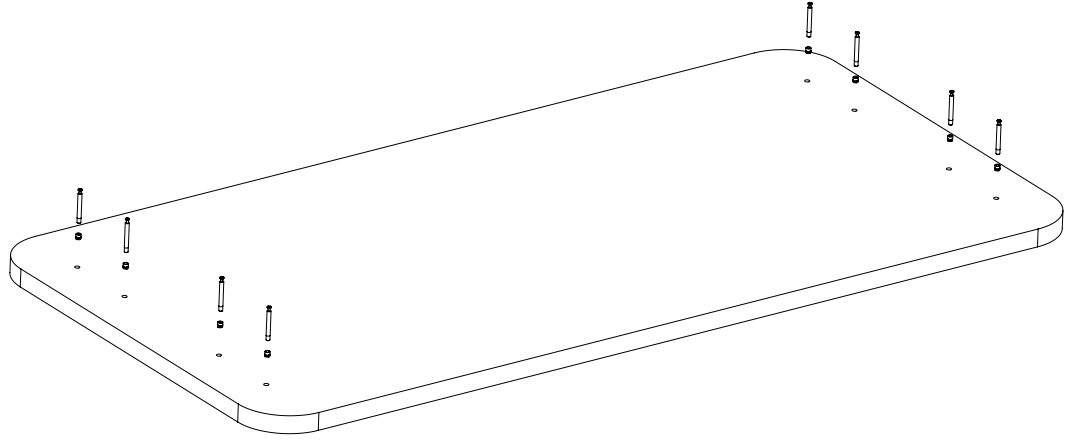

## STEP 6

Flip assembly over and add top to base assembly.

\* Side panels shown with optional bag hooks

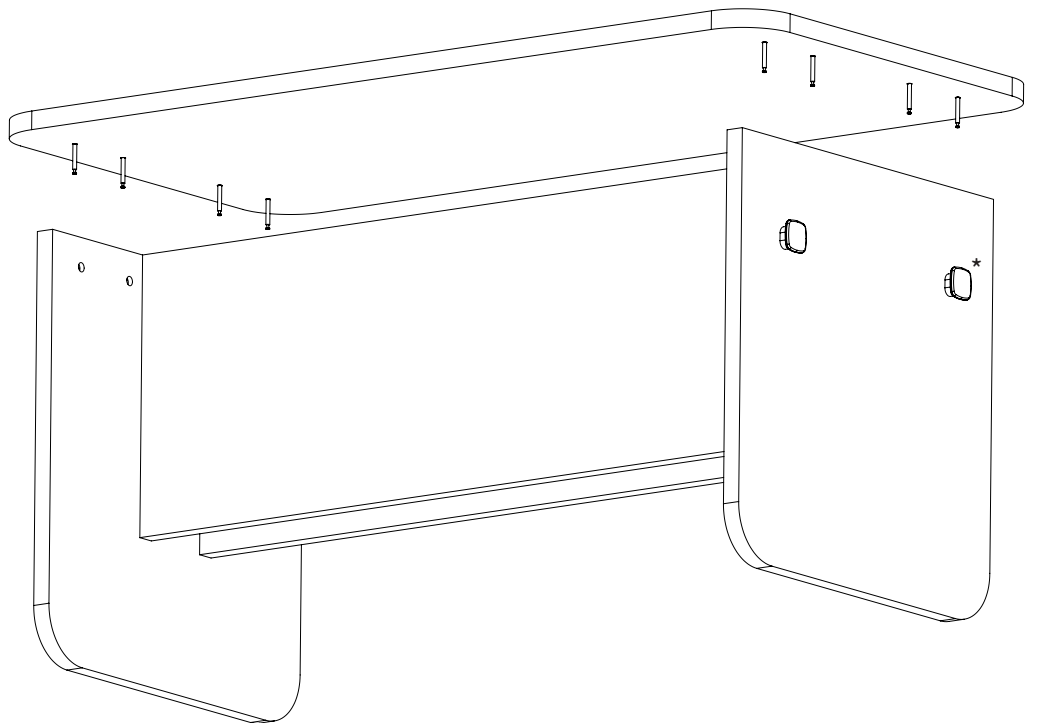

## STEP 7

Tighten all remaining cam locks attaching the top to the base assembly.

\* Side panels shown with optional bag hooks

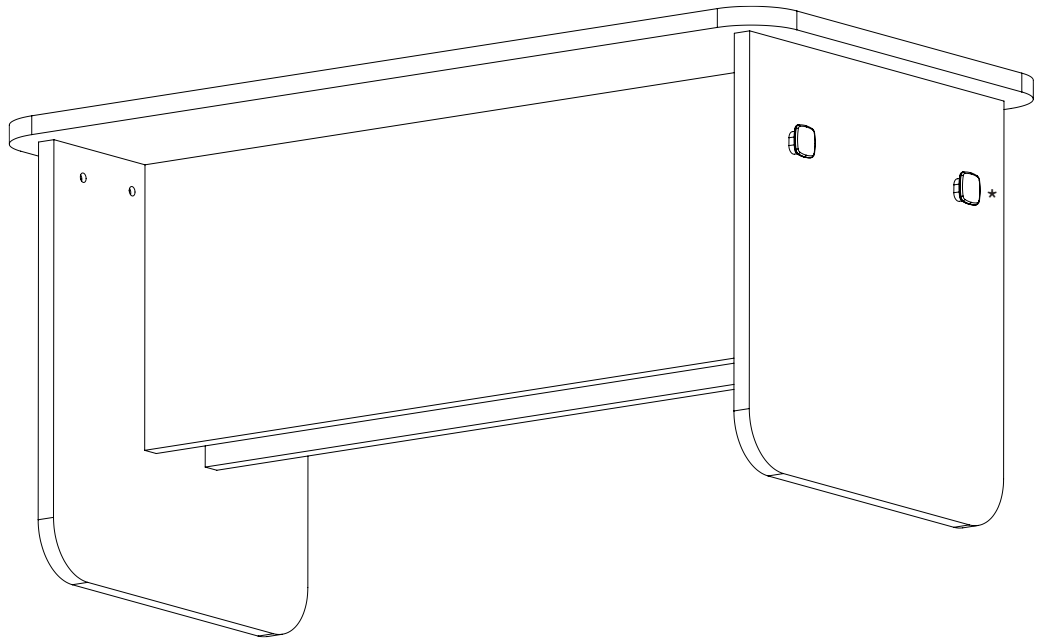

## COMPLETE

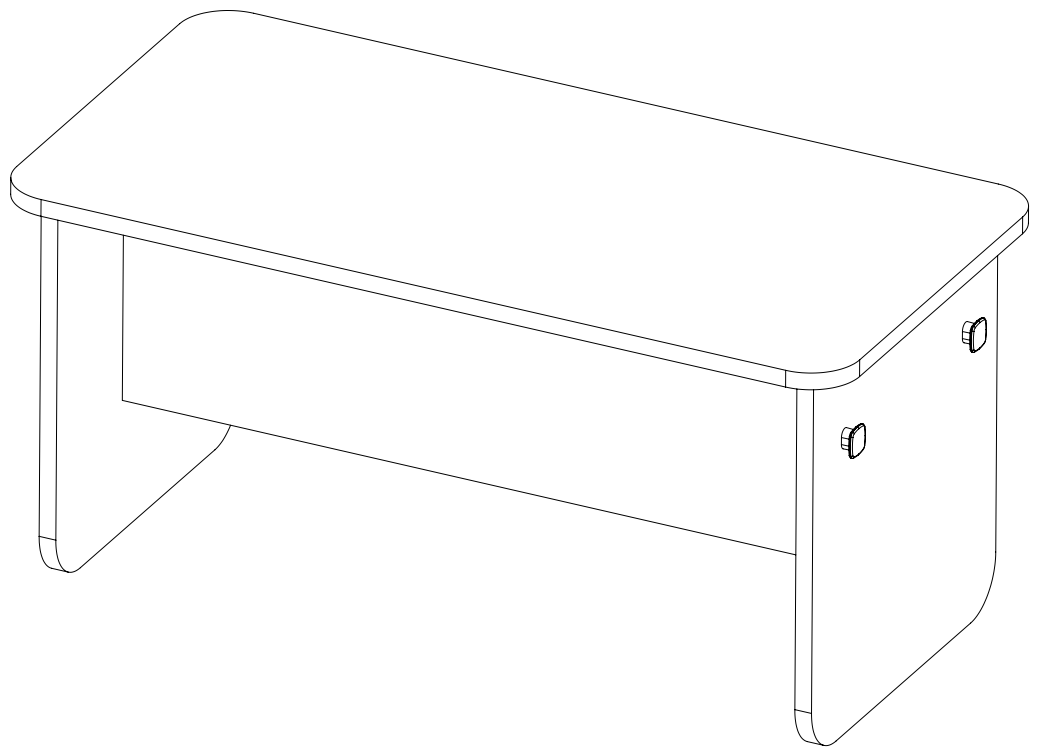

**THIS COMPLETES ASSEMBLY INSTRUCTIONS.**