

ASSEMBLY INSTRUCTIONS
DO NOT THROW AWAY!



**INSTRUCCIONES DE
ENSEMBLAJE**
NO LA TIRE

**INSTRUCTIONS DE
MONTAGE**
NE PAS JETER

Parts List

P1 - Ganged Compass Cabinets
(as specified)

x 1

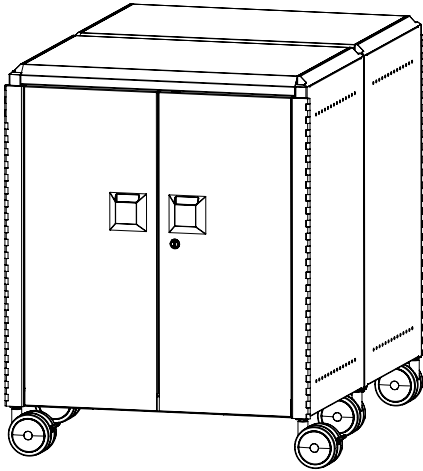

(Note: Due to the flexible nature of the sheet metal construction, the ganged cabinets may arrive with a gap. This is easily remedied by simply squeezing the two units together when installing the top in Steps 3 and 4.)

P2 - Island Top
(CR, SQ, or QD)

x 1

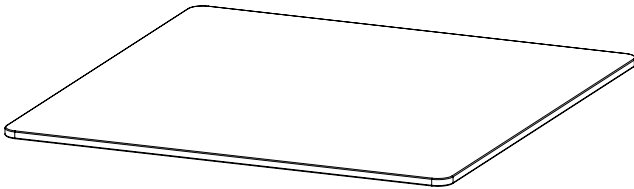

P3 - Riser

x 8

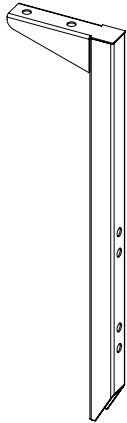

Hardware

A - #10 x 1" Wood Screws

x 16

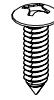

TOOLS & SAFETY

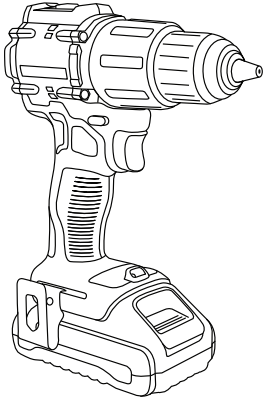

Power Drill

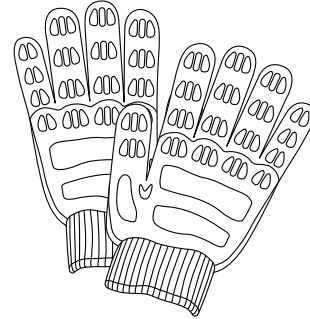

Work Gloves



#3 Phillips Screwdriver Bit

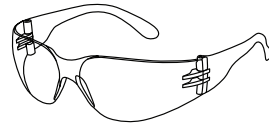

OSHA Approved Safety Goggles

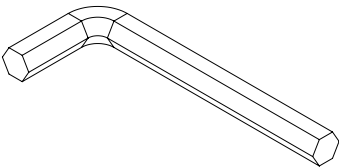

4mm Allen Wrench

WARNINGS AND DISCLAIMERS

Review full assembly instructions and check that all parts are present before beginning assembly. Heavy or large furniture may require multiple persons in order to properly assemble. If you have questions regarding assembly, contact the manufacturer before continuing. Damage due to incorrect assembly may not be covered by warranty. Do not use product unless all screws are tight. Check all screws for tightness at least every six months. If parts are broken, missing, damaged, or worn, stop use of the product until repairs are made by your dealer using factory authorized parts.

ADVERTENCIAS Y RENUNCIAS

Por favor leer las instrucciones previo a comenzar el proceso de ensamblaje o instalacion. Asegure que cuenta con todas las partes y materiales necesarios. Es posible que los muebles y tableros grandes o pesados, requieran mas de una persona para ensamblarlos/ instalarlos correctamente. Si tiene alguna duda o consulta, comuniquese directamente con el fabricante antes de continuar con el proceso de armado / instalacion del producto. La garantía no cubre daños por errores cometidos durante el proceso de ensamblaje / instalacion. Asegurese de que los tornillos esten ajustados antes de usar el producto. Se recomienda revisar los tornillos periódicamente, por lo menos cada seis meses y asegurarse de que estén bien ajustados. Por favor detenga el uso del producto si hay partes con fallas, rotas o deterioradas con tiempo. Contacte a su distribuidor para que replacen las partes o realicen las reparaciones necesarias con repuestos autorizadas por el fabricante.

AVERTISSEMENTS

Avant de commencer l' assamblage veuillez consulter les instructions complètes et vérifier si vous avez toutes les pièces nécessaires. Il est possible que plusieurs personnes soient nécessaires pour assemble des meubles grand ou lourds. En cas de doute sur l' assamblage contactez le fabricant avant de continuer. Les dommages encourus pendant l'assamblage ne seront pas couvert par la garantie. Ne pas utiliser le produit sans vérifier que tous les vis soient serrées. Vérifiez que les vis sont serrées au moins tous le 6 mois. Si aucune pièce se casse, manque, est endommagée ou usée, arrêtez d' utiliser de produit jusqu'à ce que le vendeur le repaire a l'aide de pièces autorisées par la fabricant.

WARRANTY

For full product warranty details, please visit:

Para obtener información sobre la garantía del producto, consulte este sitio (ingles):

Pour plus d'informations sur la garantie du produit, consultez ce site (anglais):

<https://moorecoinc.com/warranty>

CARE & MAINTENANCE

For questions on assembly or missing/damaged parts, please contact us using the following information.

Para preguntas sobre el ensamblaje o piezas faltantes o dañadas, por favor contáctenos usando la siguiente información.

Pour toute question sur le montage l'assamblage manquantes ou endommagées, veuillez nous contacter en utilisant les l'information ci-dessous.

Email:

support@moorecoinc.com

Phone:

1-800-749-2258

(Monday – Friday, 8am – 5pm
Central Time)

PRODUCT REGISTRATION

To register your product for warranty, please visit:

Para registrar la garantía del producto, vea este sitio (en ingles):

Pour enregistrer la garantie de votre produit, consultez ce site (en anglais):

<https://moorecoinc.com/register>

STEP 1

For both ganged cabinets: Take out drawers if necessary. Remove casting retainer screws from positions shown inside cabinet. Set screws aside. Repeat for other side of cabinet.

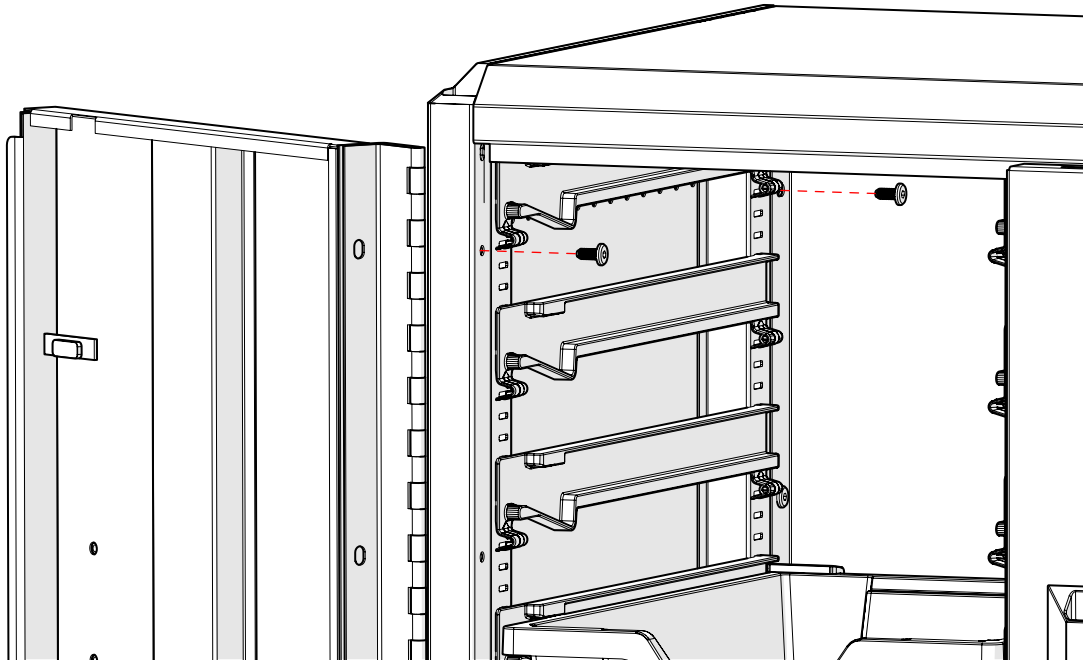

STEP 2

For both ganged cabinets: Insert Risers into slots in mount castings. Replace screws removed in previous step being careful to raise Risers to equal heights when lining up screw holes. (For proper height adjustment see Support Height Addendum on page 7.)

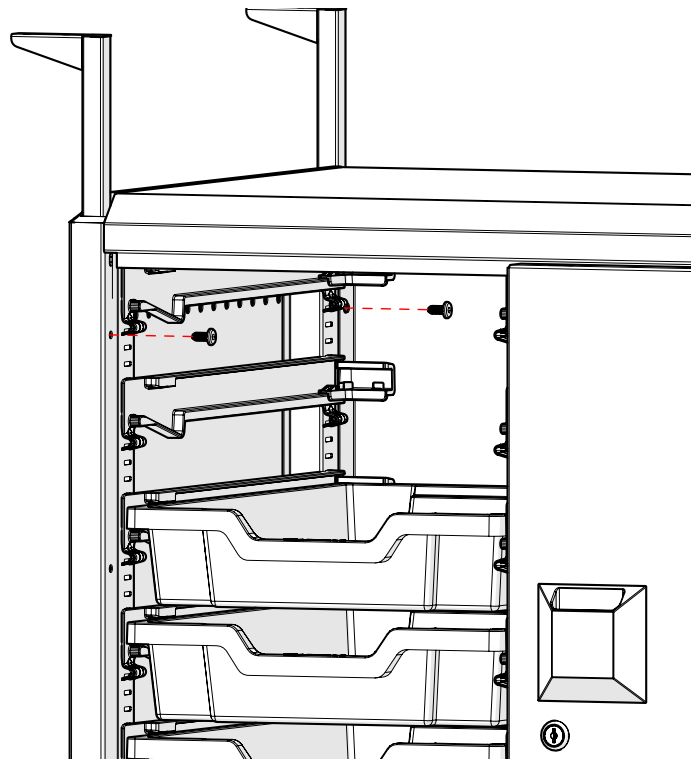
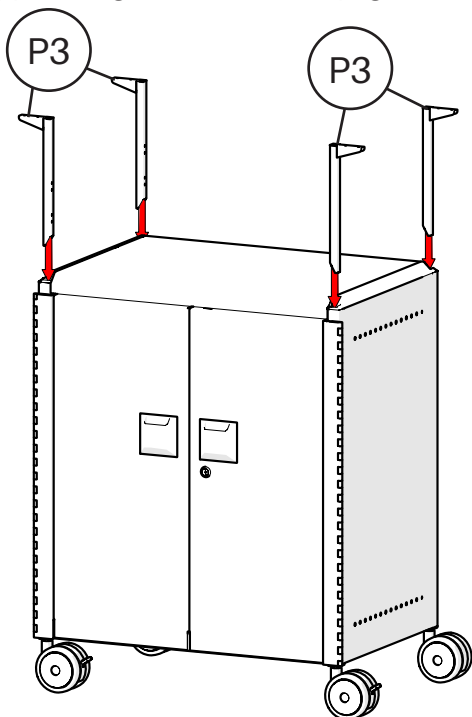

STEP 3

Using pre-drilled holes in bottom of Island Top as guides, align top to holes in cabinet top panel.

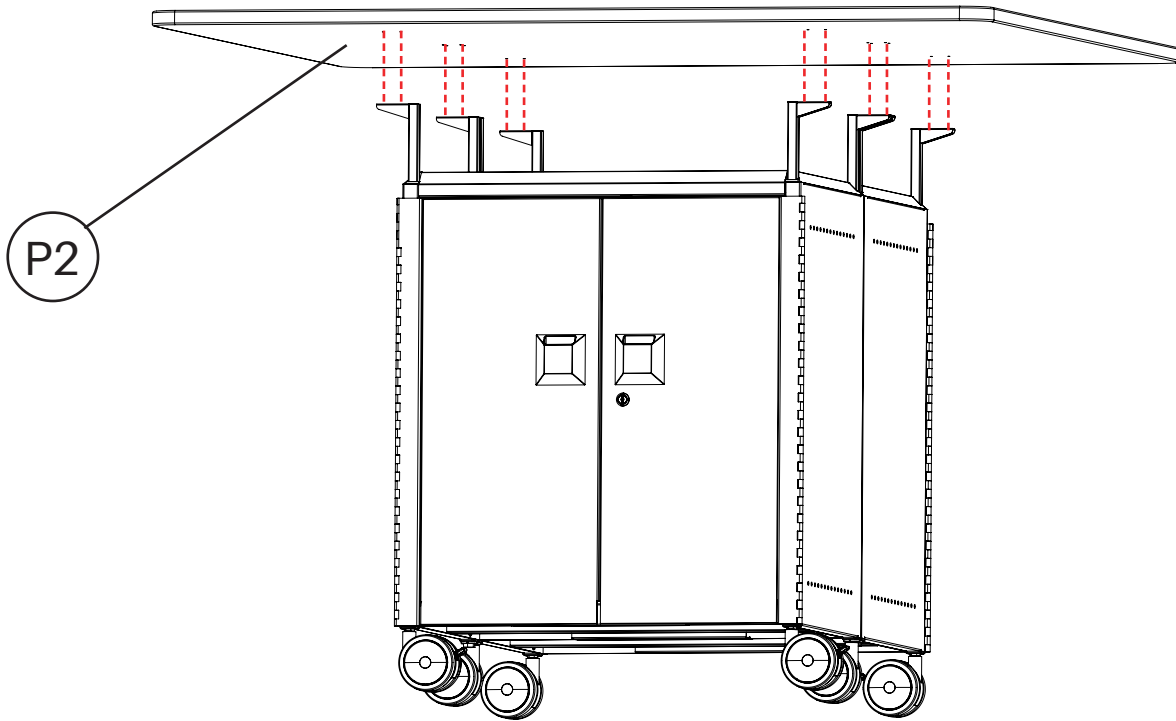

STEP 4

Using pre-drilled holes in bottom of Island Top as guides, secure top to surface of cabinet with wood screws driven into the Top through the holes in each of the Risers.

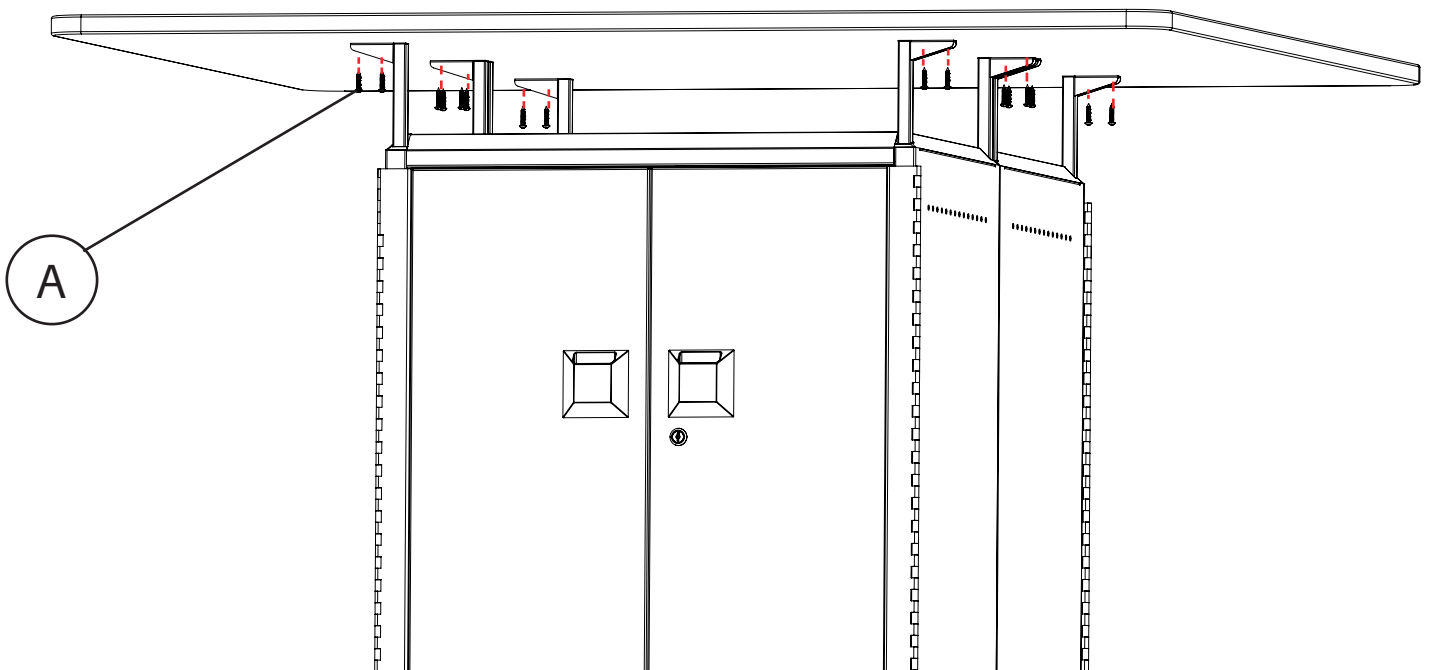

THIS COMPLETES ASSEMBLY INSTRUCTIONS.

SUPPORT HEIGHT ADDENDUM

Use the distances below while setting Support Tubes in Step 2 to ensure correct transaction top height. Distances are provided for each of three cabinet height options and are measured from ground to top of Support Tube.

